

Zone Boundary Magnet Installation

The OvenRIDER® NL has reed switch sensors designed for locating the start of oven magnets that is mounted at the beginning of the first heated zone in the reflow oven. These sensors are on one side of the front and back edges. The OvenRIDER® NL Kit includes 3 magnets for installing up to 3 ovens.



Some components contain materials that are attracted to magnets (IC legs, component leads, mounting hardware, etc). Although the magnets installed for the OvenRIDER® NL zone detection are relatively weak, they may attract these components if they get less than 0.5 inches (12cm) from the magnets. If the components on the PCB are too close, be sure they are well secured, or that they do not contain magnetic material.

The Following steps assist you to properly install the zone boundary magnets:



When unpacking be careful not to sharply jar the magnets because it can weaken their magnetization.

1. The zone boundary magnet kit is supplied with two different types of magnet clips designed to mount the magnets to the reflow oven rail. Reflow ovens may have different conveyor rails than the one used in this explanation, so determine which type will best mount the magnets in your oven. Modifications to the clips may be necessary to properly mount magnets.

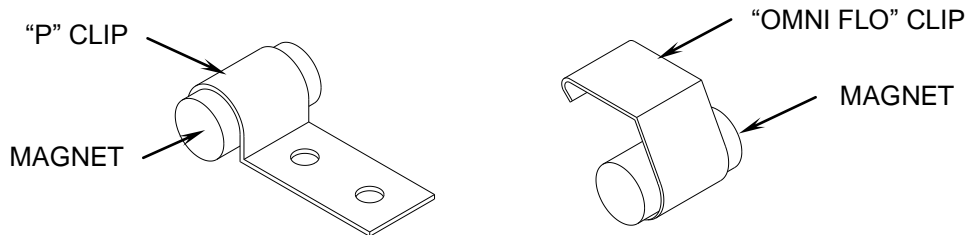

Figure 1-1: Magnet Clips

2. Open the top of the oven and determine where to place the start of the first zone magnet.
3. Adjust the conveyor to match the OvenRIDER® NL width. (The width of the OvenRIDER® NL pallet is engraved on the back edge of the pallet top.)
4. Slide the OvenRIDER® NL on the conveyor until the front sensor reaches the magnet.

OVER ↴

- Center a magnet and clip on the first zone boundary within .5" to 1.0" (1.3-2.5cm) from the edge of the OvenRIDER® NL pallet and slide the OvenRIDER® NL past the magnet.

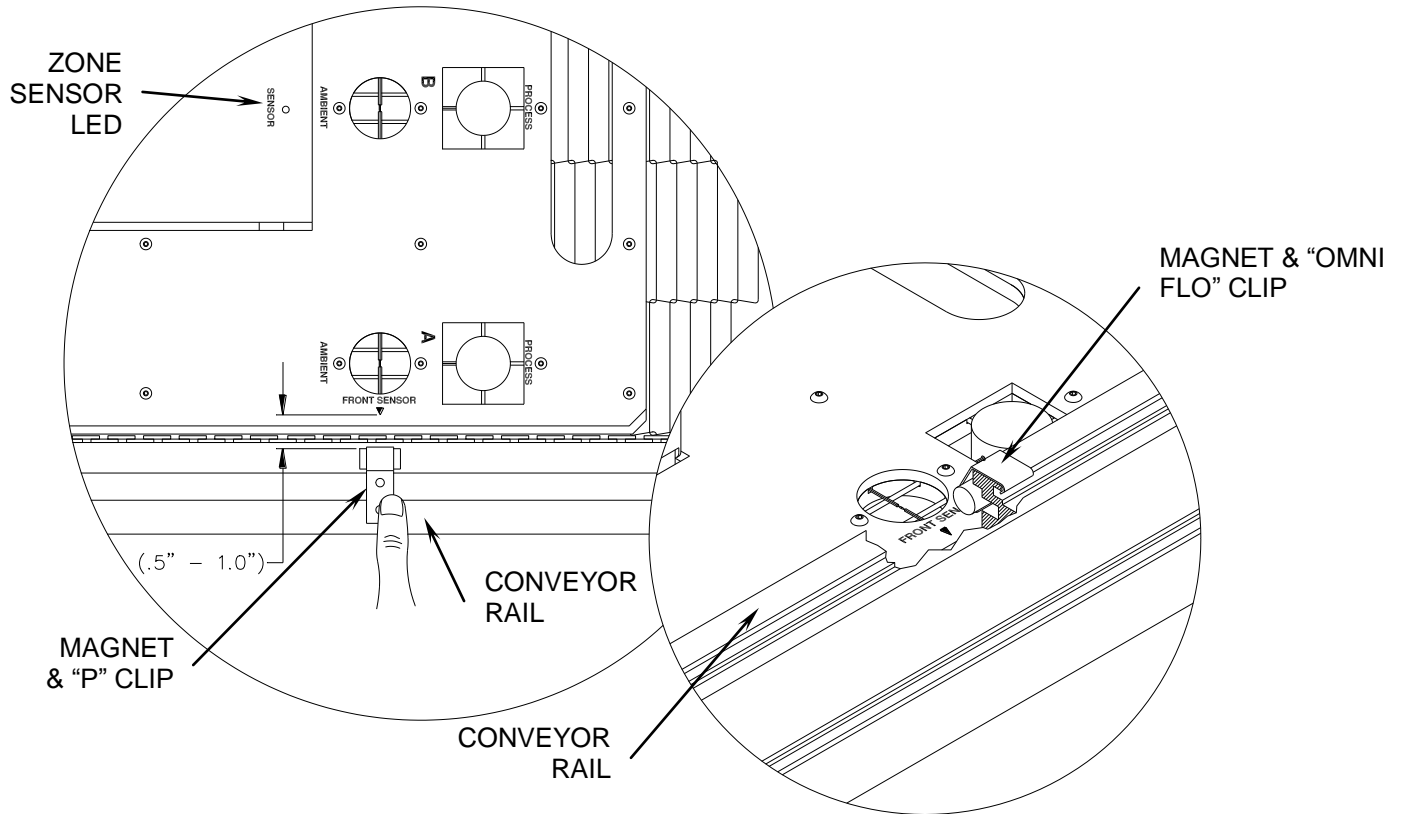

Figure 1-2: Magnet Alignment

- When the OvenRIDER® NL front and rear zone sensors pass the magnet, the OvenRIDER® NL zone sensor LED located on the top front of the barrier box must illuminate and stay illuminated for .75" +/- .25" (1.9cm +/- .6cm) while each sensor has moved past it. Use the measuring scale on the edge of the pallet for a reference.
 - When the OvenRIDER® NL passes the magnet, the Sensor LED must not double flash. If this occurs the magnet is placed too close to the OvenRIDER® NL pallet sensor.
- When the magnet is properly aligned mount the "P" clip securely by tapping and drilling for a #6 or 8 screw. If the "OMNI FLO" clip is being used, simply clip it to the rail and slide it into the desired position. Using the *Manual Zone* feature in the OR SPC software, you can make an oven model by measuring from the magnet to the center between zones for all the other zones.



Periodically check the magnet installation to be sure they are clean and that nothing has attached to them. Objects attached to the magnets may disturb components on the PCB while being soldered.